



KS 3000 Heated Scanner Series



Durability and Performance for Extreme Temperatures

The KS 3000 Series of heated scanners represents another breakthrough from the industry leader in bar code data collection. The KS 3000 Series of scanners are optimized for extremely low temperature environments and are designed to eliminate exit window condensation when moving from the freezer to normal room temperatures. Available in four models, the KS 3000 Series brings scan decode read ranges of up to 35 ft. (10m) into freezer and cold storage applications.

LS 3000 Performance

The KS 3000 Series is the latest addition to the LS 3000 line of award-winning industrial hand-held scanners from Symbol. With over 500,000 units already sold, the LS 3000 line leads the way in unsurpassed reliability and performance over a wide variety of industrial, commercial and rugged retail applications. To create the KS 3000 Series, Symbol Technologies has integrated an internal heater element with a circulating fan into four of the most popular LS 3000 models. Now you can have clear, condensation and frost-free operation in freezer applications as low as -30°C (-22 °F) along with the extended range performance of the LS 3200ER. Or for applications demanding the ability to read poorly printed or damaged bar codes, Symbol offers with the 'fuzzy logic' performance with the integrated heater in the KS 3603.

Multiple Configurations

There are four KS 3000 models to choose from: For extended range applications the KS 3200ER undecoded and the KS 3203ER decoded scanners can read up to 35 ft. (10m) on 100 mil labels. For standard range applications

Symbol offers the decoded KS 3603 with 'fuzzy logic' or the undecoded KS 3200. The four models give the user, or system integrator, the ability to choose decoded or undecoded, long range or standard range. Data interface options include built-in RS-232 and wand emulation for the decoded models as well as support for most other host systems via Symbol's Synapse™ smart cables. Any LS 3000 data cable will work with the KS 3000 Series.

Fork Truck Ready

The KS 3000 scanner packages come complete with a universal power supply for connection to all standard fork trucks. The power supply takes input voltage from 20 to 72 VDC and supplies power to the heating elements separately from the data connection.

To find out more about the KS 3000 Series of heated scanners and how they can improve your productivity, contact any of our convenient locations listed on the back address panel, or visit us at www.symbol.com

KS 3000 Heated Scanners

- *LS 3000 Series performance with internal heating element*
- *Four versions available: Standard Range, Extended Long Range, Decoded and Undecoded configurations*
- *Supports all fork truck applications*
- *Complete scanner solution for freezer/frozen material distribution*
- *Eliminates condensation caused by extreme/rapid temperature changes*

KS 3000 Heated Scanner Series Specification Highlights

Performance Characteristics

Light Source:	650 nm laser diode (KS 3603 & KS 3200) 675 nm laser diode (KS 3200ER & KS 3203ER)
Scan Rate:	36 (±3) scan/sec. (bi-directional)
Yaw:	± 45° from normal
Roll (skew):	± 10° from normal
Pitch:	± 45° from normal
Print Contrast:	50% minimum reflectance
Decode Capability:	(Decoded versions) UPC/EAN with supplements, Code39, Code39 Full ASCII, Code 128, EAN 128, Codabar, I 2 of 5, Discrete 2 of 5, MSI/Plessey
Interface Type:	(Decoded versions) wand emulation, RS-232C, PC and terminal keyboard wedges, OCR, Dual RS-232C IBM 468X/469X, OCIA, Bi-directional OCIA
Regulatory:	Certified to UL1950/CSAC 22.2 No. 950; complies with FCC Part 15 Class A, ICES-003 Class B, CISPRB

Physical Characteristics

Current:	Scanners; 110mA undecoded, 150mA decoded
Laser Class:	IEC Class 2, CDRH Class II
Voltage:	Scanners: 4.8 to 14 VDC
Power Supply:	Input 20 to 72 VDC, nom. 48 VDC Max Input at 20 VDC is 2A Output for heater and thermostat +12VDC@1.25A and +5VDC@ 0.18A
Weight:	Scanners with insulated cover 8.7 oz. (308 grams)
Color:	Dark Gray w/ Black insulating cover
Packages Available:	PKG-KS3200ER-001 - Undecoded Long Range PKG-KS3203ER-001 - Decoded Long Range PKG-KS3603-001 - Decoded Standard Range PKG-KS3200-001 - Undecoded Standard Range

User Environment

Ambient Light Immunity:	Incandescent light: 350 foot-candles /3,766 lux Fluorescent light: 450 foot-candles /4,842 lux Sodium vapor light: 350 foot-candles /3,766 lux Mercury vapor light: 450 foot-candles/ 4,842 lux
Operating Temperature:	-30° to 50° C (-22° to 122° F)
Storage Temperature:	-40° to 60° C (-40° to 140° F)
Humidity:	5% to 95% (noncondensing)
Durability:	Multiple 6ft (1.8m) drops to concrete
Environmental:	All components sealed against dust & water



Specifications are subject to change without notice. Synapse is a trademark of Symbol Technologies Inc.



Part No. LQ Printed in USA 6/99 ©1999 Symbol Technologies, Inc.
Symbol is an ISO 9001 and ISO 9002 UKAS, RVC, and RAB Registered company, as scope definitions apply.

KS 3603 & KS 3200 Decode Read Zone

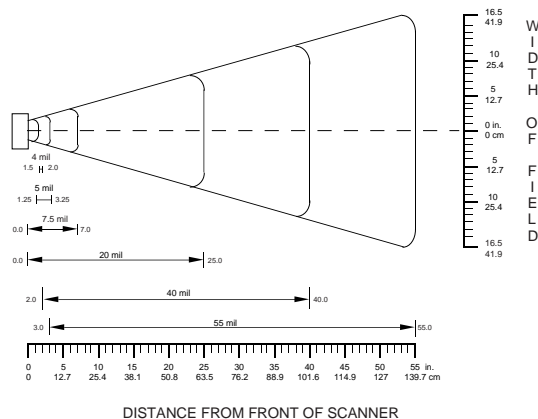

KS 3200ER & KS 3203ER Decode Read Zone

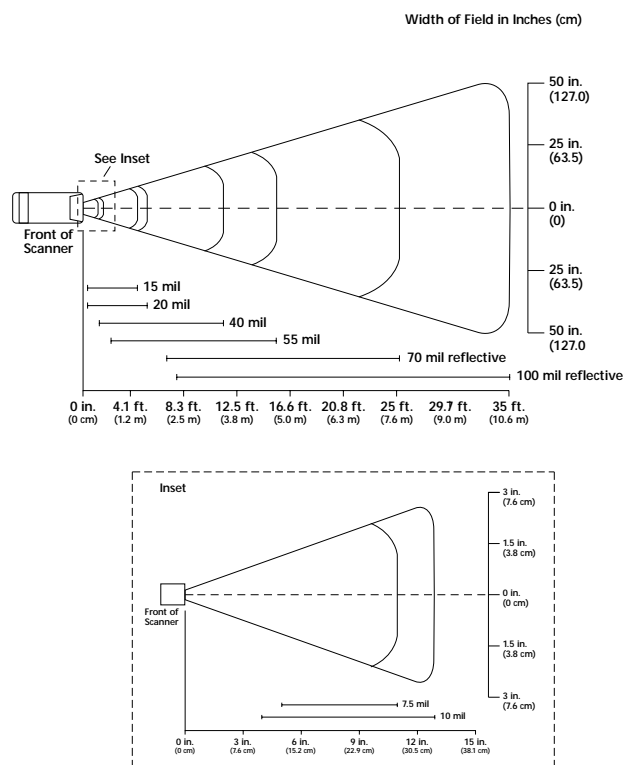

For system, product or services availability and specific information within your country, please contact our local Symbol Technologies office or Certified Business Partner.

Symbol Technologies, Inc.
Corporate Headquarters
One Symbol Plaza
Holtsville, NY 11742-1300
TEL: 1-800-722-6234/1-516-738-2400
FAX: 1-516-738-5990

For North America and Latin America
Symbol Technologies
The Americas
One Symbol Plaza
Holtsville, NY 11742-1300
TEL: 1-800-722-6234/1-516-738-2400
FAX: 1-516-738-5990

For Europe, Middle East and Africa
Symbol Technologies
EMEA Division
Symbol Place, Winnersh Triangle
Berkshire, England RG41 5TP
TEL: 44-118-9457000
FAX: 44-118-9457500

Symbol World Wide Web Internet Site
For a complete list of Symbol subsidiaries and
Symbol Business Partners worldwide contact
us at:
<http://www.symbol.com>
E-mail: webmaster@symbol.com

For Asia Pacific
Symbol Technologies Asia Inc.
(Singapore Branch)
Asia Pacific Division
230 Victoria Street #04-05
Bugis Junction Office Tower
Singapore 188024
TEL: 65-337-6588/FAX: 65-337-6488



About BarcodesInc

Who We Are

BarcodesInc is North America's leading provider of barcode and mobile computing solutions. We are a leading provider of barcode and mobile computing solutions. We are a leading provider of barcode and mobile computing solutions. We are a leading provider of barcode and mobile computing solutions.

We Owe Our Success To You

Our success is due to the support and partnership of our customers. We are a leading provider of barcode and mobile computing solutions. We are a leading provider of barcode and mobile computing solutions. We are a leading provider of barcode and mobile computing solutions.

Why Choose BarcodesInc?

Dedicated Account A UbU Yf

Our Account Managers will not compromise when it comes to providing you top-notch service. Your Account Manager is the primary point of contact for your business and makes it a priority to get to know you, your company and all your needs.

Highly-Trained Technical Support

Our technical staff has the broadest knowledge and every significant certification in the industry. One of our friendly experts is always available to suggest products and solutions for any situation.

Incredible Value

Our purchasing power means big savings for you. Whatever your project, our team will work hard to deliver a solution that fits your budget.

Largest Inventory in the Industry and Same-Day Shipping

Whatever your barcoding, mobile computing, or printing needs, we will fill your order and ship it the same day.

Premier Access to Top Manufacturers

BarcodesInc maintains strong strategic partnerships with the leading manufacturers in barcoding, mobile computing, printing and RFID.

Responsive Customer Service

Every phone call and email is responded to promptly, completely and accurately by our customer service team.

Easy Returns

Damaged, defective or incorrectly ordered goods may be returned without hassle.

BRANDS

