

# MS200 Series **Stratos**<sup>®</sup>

## OPERATIONAL

Light Source	Visible Laser Diode 650 nm ± 10 nm
Laser Power - (horz/vert)	1.25 mW / 2.25 mW
Depth of Scan Field - (horz)	0 mm - 152 mm (0" - 6.0") for 0.33 mm (13 mil) bar code
Depth of Scan Field - (vert)	0 mm - 216 mm (0" - 8.5") for 0.33 mm (13 mil) bar code
Scan Speed	6000 scan lines per second
No. of scan lines - (horz/vert)	68 (40 / 28)
Motor Speed - (horz/vert)	4800 / 6000 RPM
Sides Read	6
Scan Zone	360°
Minimum Bar Width	0.152 mm (6.0 mil)
Decode Capability	All standard 1-D bar codes, RSS-14, RSS-Expanded, RSS-14 Limited
System Interfaces	RS-232, Aux. RS-232, IBM468x/469x, USB (low speed and full speed), OCIA
Print Contrast	35% minimum reflectance difference
Number Characters Read	Up to 80 data characters
Roll, Pitch, Yaw	360°, 60°, 60°
Speaker Operation	7 tones or no beep; - 3 volume settings
Indicators (LED)	Blue = laser on, ready to scan; White = good read, decoding

## MECHANICAL

Length	MS200 (full size scanner with scale)	508 mm (20.0")
	MS201 (full size scanner only)	508 mm (20.0")
	MS202 (compact size scanner only)	420 mm (16.5")
Width	286 mm (11.3")	
Depth (below counter)	100 mm (4.0")	
Height (above counter)	178 mm (7.0")	
Weight	MS200 (full size scanner with scale)	11.8 kg (26 lbs)
	MS201 (full size scanner only)	7.7 kg (17 lbs)
	MS202 (compact size scanner only)	7.3 kg (16 lbs)

## SCALE CAPACITIES

Capacity	15.0 kg (30.0 lb)
Minimum increment	0.005 kg (0.01 lb)
Maximum static weight	68 kg (150 lb)
Adjustments required	Calibration only

Input Voltage	5V @ 1.5 Amps / 12V @ 1.5 Amps
Power	13.5 Watts (when scanning); 5 W (standby)
Operating Current	900 mA (5V) / 700mA (12V)
DC Transformers	Class II; 5 VDC @ 1.5 A; 12 VDC @ 1.5 A
Laser Class	CDRH & IEC: Class 1 according to IEC 60825-1:1993+A1:1997+A2:2001
EMC	FCC, ICES-003 & EN55022 Class A

Operating Temperature	0°C to 40°C (32°F to 104°F)
IP Rating	IP 55
Light Levels	4842 Lux (450 footcandles)
Storage Temperature	-40°C to 60°C (-40°F to 140°F)
Humidity	5% to 95% relative humidity, non-condensing
Contaminants	Sealed to resist airborne particulate contaminants
Ventilation	None required

## Dimensions

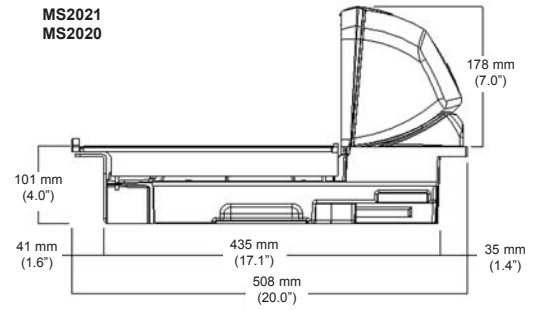
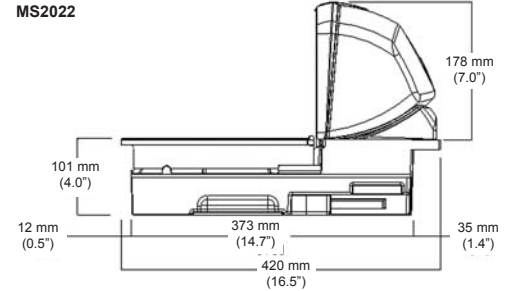
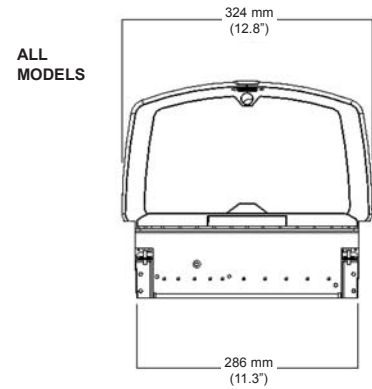

**ISO 9001:2000**

Sunrise 2005 Compliant



www.metrologic.com

**USA**  
Tel. 1.800.ID.METRO  
info@metrologic.com

**Asia**  
Tel. 65.6842.7155  
info@sg.metrologic.com

**AOA (only)**  
Tel. 1.617.806.1400  
info@aoa.metrologic.com

**China (only)**  
Tel. 86.512.62572511  
info@cn.metrologic.com

**South America**  
Tel. 5511.5182.7273  
info@sa.metrologic.com

**Japan (only)**  
Tel. 81.03.3839.8511  
info@jp.metrologic.com

**Brazil (only)**  
Tel. 5511.5182.8226  
info@br.metrologic.com

**Europe**  
Tel. 49.89.89019.0  
info@europe.metrologic.com

Metrologic Instruments, Inc. | 90 Coles Road | Blackwood, NJ 08012-4683  
Telephone 856-228-8100 or 1-800-ID-METRO | Fax 856-228-6673

Specifications subject to change without notice.  
Printed U.S.A., Copyright November 2003  
Metrologic, All rights reserved.



DS2020



The pursuit of the perfect in-counter scanner:  
**open up our newest chapter.**



Introducing Stratos®  
Metrologic's high performance  
6-sided bi-optic in-counter scanner/scale series.

**Designed for the most demanding, high volume,  
supermarket and point-of-sale applications.**



# 35 Years of Innovation, Value and Service

Satisfying customer expectations. We've been doing it since 1968.



Corporate Headquarters, Blackwood, New Jersey, USA



From the warehouse to the distribution center to the checkout, Metrologic takes pride in serving retail, hospitality, healthcare, manufacturing, transportation, logistics and a host of other markets with superior point-of-sale and automatic data capture products. At Metrologic, we don't just respond to the changing needs of our customers and their markets. We anticipate them. By doing so we not only innovate, we foster strong relationships with our customers.

Stratos marks the beginning of a new era; the current destination in our pursuit of perfection. With Stratos we introduce a true flagship. A product that delivers significant advances and sets new standards in high-volume POS scanning. Based on years of experience and carefully considered anticipations, our engineers explored a number of innovative avenues and created the highest performing bar code scanner in an industry-leading package. Congratulations to us. Good news for you.

And if its more than high performance bi-optic scanning that you're after, you're in good hands. Stratos joins a strong family of POS hand-held, fixed and mini-slot scanners; portable terminals; miniature scanning engines; and over-the-belt industrial scanners and image acquisition systems. We provide features, value and service to customers in more than 100 countries through a growing network of sales, service and distribution offices in North and South America, Asia and Europe. We are determined to offer honest and fair dealings with every customer who does us the honor of pursuing business with Metrologic.



Stratos**SCAN**™ Stratos**SWAP**™ Strat

**SPEED**



>> **RSS-14 Decoding**

Decodes RSS-14, RSS Limited and RSS Expanded emerging symbologies in addition to all standard 1D bar codes.



From its brilliant blue indicator to its smooth charcoal body and black accents, Stratos exudes quality and beauty. Its tasteful

above-counter design speaks of its high-performance upbringing. In fact, everything about Stratos is purposeful; designed to take high-volume POS scanning to new heights.

**Speed. Because you don't want your customers waiting in line.** Time is money. And nowhere is that more apparent than at the checkout. With Stratos**SCAN**™ 6-sided, 360° scanning, advanced Stratos**SPHERE**™ decoding software, 6000 scans per second, and a class-leading 68 scan lines, Stratos' performance is sure to get customers through fast. And thanks to Stratos**SCAN**, operators also benefit from minimized fatigue and stress associated with twisting and turning products.

**Uptime. Because you don't want your scanner waiting for a repair technician.** You only have a certain number of lanes per store. Each needs to be ready for action when it's convenient for your customers. That's why Stratos is constructed like a tank and tested to withstand the rigors of today's checkout environment. But we've faced reality,

scanners sometimes malfunction, so Metrologic invented Stratos**SWAP**™ modular optics engine technology – small, pre-aligned, field-replaceable modules that pop into place in a matter of minutes. Simple. No need for full-unit spares taking up warehouse space. No need for degreed engineers on-call. What's more, Stratos' vertical and horizontal scanning zones operate totally independently one from another – a feature we call Stratos**SYNC**™. If one goes down, the other keeps scanning to keep your customers moving.

**Return on investment. Because we don't want you waiting to realize increased profit.** It starts with value pricing. Then we add features like Stratos**SCHOOL**™ operator training software and Stratos**STATS**™ code checking software to monitor characteristically hard-to-scan codes, a solid "bumper to bumper" warranty and, because every dollar counts, our light 15lb. (non-scale) unit even

costs less to ship.

**So why are you waiting?** There's no better time to consider replacing your old flatbed scanners, upgrading your existing 4- and 5-sided dual-plane scanners or upgrading to a scanner/scale. Call us or click on the new products banner at [www.metrologic.com](http://www.metrologic.com).

From the Counter Down  
(a scant 4 inches might we add)  
Stratos is Designed for Speed, Uptime and Return on Investment.

Stratos**SCHOOL**™ Stratos**SCOPE**™ Stratos**STATS**™ Stratos**SPHERE**™ Stratos**SYNC**™

# SERVICEABILITY



**>> StratosSWAP**  
Field replaceable optical scanning modules can be replaced in minutes.

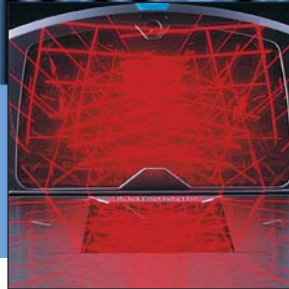

**>> StratosSYNC**  
Independent vertical and horizontal scan zones



**>> StratosSCOPE**  
Visual diagnostic indicator provides immediate, easy-to-read feedback on scanner condition.

# StratosSCAN

6-sided, 360°, scanning technology



**Bright Blue and White LEDs**  
Easy to see scan and good read indicators.

**Multi-function Push Buttons**  
Operator-side volume, sleep and scale zero controls.

**Field Replaceable Vertical Window**  
Quickly remove vertical window for cleaning or replacement.

**Debris Guard**  
Eliminates debris from interfering with scale operation.

**Stainless Steel Platter**  
Easily removed for cleaning, debris removal or replacement.

**Scratch Resistant Window**  
Equipped with Diamonex® or Sapphire horizontal window.

**High Impact Window Frame**  
Designed to withstand demanding POS environments.

**100 mm (4 in.) Below Counter Depth**  
Thinnest of all high performance, 6-sided bi-optic scanners.

**Product Weight/Roll Bar**  
Reduces shrink from overhanging produce.

## Features Set Stratos Apart

- >> **100 mm (4 in.) Below Counter Depth**  
Thinnest of all high performance, 5-6 sided bi-optic scanners.
- >> **StratosSCAN**  
6-sided, 360° scanning minimizes product orientation.
- >> **StratosSPHERE Decoding Software**  
Reads poor quality and damaged bar codes.
- >> **BackPack™**  
Customer interaction peripheral system.
- >> **Easy to Install**  
Fits existing counter openings.
- >> **Flash ROM**  
Upgrade latest software enhancements on-site.
- >> **Powered Aux Port**  
Connect hand-held scanner for large or bulky items.
- >> **RSS-14 Decoding**  
Decodes RSS-14, RSS Limited and RSS Expanded emerging symbologies.
- >> **Integrated Scale**  
Factory integrated or field upgradeable scale.
- >> **Loud Speaker**  
3 volume/7 tone settings can be heard in all environments.
- >> **Easy Programming**  
Windows® based utility or simple bar code setup.
- >> **Fully Automatic**  
“No touch” infrared wake up from power save modes.
- >> **EAS Deactivation**  
Electronic Article Surveillance (EAS) included.
- >> **Spill Channel**  
Channels spills and debris away reducing maintenance.



## About BarcodesInc

### Who We Are

BarcodesInc is North America's leading provider of... [The following text is intentionally obscured with noise for this block]

### We Owe Our Success To You

Our success is due to our commitment to... [The following text is intentionally obscured with noise for this block]

## Why Choose BarcodesInc?

### Dedicated Account A UbU Yf

Our Account Managers will not compromise when it comes to providing you top-notch service. Your Account Manager is the primary point of contact for your business and makes it a priority to get to know you, your company and all your needs.

### Highly-Trained Technical Support

Our technical staff has the broadest knowledge and every significant certification in the industry. One of our friendly experts is always available to suggest products and solutions for any situation.

### Incredible Value

Our purchasing power means big savings for you. Whatever your project, our team will work hard to deliver a solution that fits your budget.

### Largest Inventory in the Industry and Same-Day Shipping

Whatever your barcoding, mobile computing, or printing needs, we will fill your order and ship it the same day.

### Premier Access to Top Manufacturers

BarcodesInc maintains strong strategic partnerships with the leading manufacturers in barcoding, mobile computing, printing and RFID.

### Responsive Customer Service

Every phone call and email is responded to promptly, completely and accurately by our customer service team.

### Easy Returns

Damaged, defective or incorrectly ordered goods may be returned without hassle.

## BRANDS



AND MORE