

Z-2060 Series

Windows CE.NET Handheld Computer



- Large 3.5" TFT QVGA color display with touch panel
- 1D laser & 2D image scanner options
- Superior Microsoft® Windows® CE.NET 5.0 operating system and Intel 520 MHz CPU
- Ergonomic and rugged design, qualified with IP64 industrial standard
- 5,000 mAH 3.7V Li-ion recharged smart battery
- Mini SD I/O slot for extra storage expandability
- Easy system control tools – Power Pack, saving time and money in software development

◀ Actual size



⚠ Product availability and specifications depend on territory market strategy; all are subjects to change without prior notice. ZEBEX is the trademark of ZEBEX INDUSTRIES INC., all rights reserved.

ZEBEX
www.zebex.com

[Dimensions]

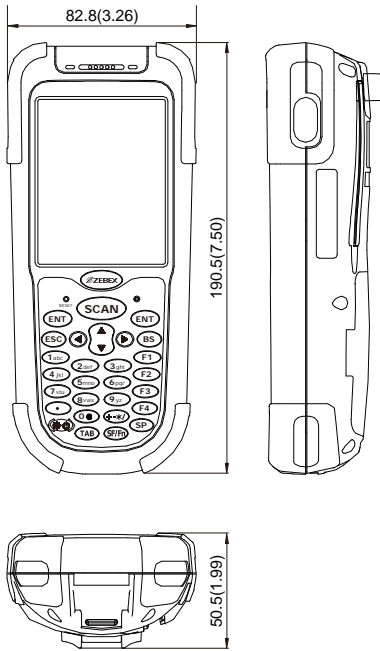

Unit: mm(inch)

[Scan Field] - 1D Laser

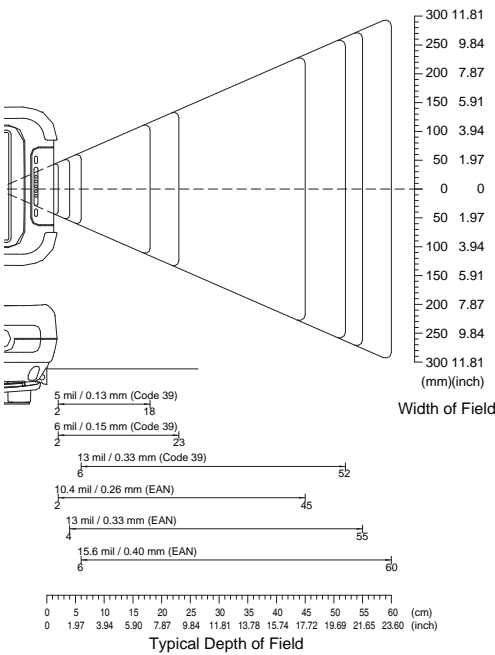

[Specifications]

SYSTEM	
CPU	Intel PXA 270 520 MHz processor
Operating System	Microsoft® Windows® CE.NET 5.0
RAM	128MB
F-ROM	64MB
Display (LCD)	3.5" TFT QVGA 240x320 color display with touch panel
Audio	One audio jack, one speaker, one microphone
Keypads & Buttons	Total 31-key incl. two side scan buttons for full alpha/numeric input and system control
Interfaces	IEEE802.11 b/g, Bluetooth® Class 2, RS-232, USB 1.1 Client, IrDA 1.3
Expansion Slot	One mini-SD I/O card slot
POWER	
Main Battery	5,000 mAh, 3.7V, Li-Ion rechargeable battery
Backup Battery	120 mAh, 3.7V, Li-Poly rechargeable battery
SCANNER	
Engine Type	1D laser scanner (2D, RFID optional)
Light Source	650 nm visible laser diode (VLD)
Scan Rate	100 scans per second
Print Contrast	30% @ UPC/EAN 100%
PHYSICAL	
Dimensions	(L)190.5 x (W)82.8 x (H)50.5 mm
Weight	Approx. 480 g (battery included)
ENVIRONMENTAL	
Operating Temperature	0°C – 50°C (32°F – 122°F)
Storage Temperature	-10°C – 60°C (14°F – 140°F)
Operating Humidity	10% – 70% RH (non-condensing)
Storage Humidity	5% – 70% RH (non-condensing)
Drop Durability	Withstand 1.2M (4 feet) drop to concrete
Environmental Sealing	IP64 rated sealing
REGULATORY	
EMC	CE & FCC Part 15B, 15C

[Model Selections]

Model	Scanner	WLAN	Bluetooth®
Z-2060BA	1D laser	—	—
Z-2060WL	1D laser	●	●
Z-2062BA	2D image	—	—
Z-2062WL	2D image	●	●

[Accessories]

- Cradle (including RS-232 and USB cables for communication and charging)
- Communication cables (RS-232 and USB I/F)
- Standard battery pack
- AC adaptor DC 9V, 2A
- Hand strap

